

STAC

TITÁN

herraje para correderas sliding window hardware



more than you see



stac.es

Línea TITÁN

herraje de correderas
sliding window hardware



Mecanizados simples

Simple machining



Instalación rápida

Quick installation



Sin tornillería vista

No visible screws



Carta de colores RAL

RAL colour chart

TITÁN

Soluciones idóneas para proporcionar el máximo confort y seguridad a tu ventana corredera

En los últimos años las ventanas de apertura corredera están experimentando una evolución notable en cuanto a prestaciones y confort de uso.

Esta evolución, enfocada principalmente a satisfacer los actuales requisitos de eficiencia termo-acústica, implica perfiles con amplias roturas de puente térmico y vidrios de espesores considerables.

Por todo ello, el ancho de los perfiles ha crecido sustancialmente, haciendo evolucionar de forma considerable los herrajes encargados de darles vida.

» Mecanizados simples e instalación rápida

Facilitamos la instalación de toda la línea de productos a través de mecanizados prácticos y de fácil ejecución, reduciendo de forma considerable los tiempos de montaje.

» Sin tornillería a la vista

La fijación al perfil de los diferentes productos se realiza sin tornillería a la vista, ofreciendo de esta manera una línea moderna, limpia y elegante.

» Personalización a través del color

Disponible en lacado blanco o negro y en los colores de la carta RAL, un sistema de combinación de tonalidades que define colores para pinturas, plásticos y recubrimientos.

The ideal solutions to provide maximum comfort and security for your sliding window.

In recent year sliding opening windows have evolved significant developments in terms of performance and ease of use for the end customer.

This evolution is focused primarily on meeting the current demands of thermal and acoustic efficiency. This results in profiles with ample thermal breaks and panes of considerable thickness.

For these reasons, the width of the profiles has grown substantially and this has meant an evolution in the hardware that brings them to life.

» Simple machining and quick installation

We facilitate the installation of the entire product range through practical and easy-to-execute machining, considerably reducing assembly times.

» No visible screws

The different products are fastened to the profile without visible screws, thus offering a modern, clean and elegant line that leaves no one indifferent.

» Personalisation through colour

Available in white or black lacquer as well as in the colours that make up the RAL colour chart, a colour matching system that defines colours for paints, plastics and coatings.



» Cierres de embutir recessed handles

034000 ** **CIERRE DE EMBUTIR TITÁN SIN LLAVE** TITAN RECESSED HANDLE W/O KEY

034100 ** **CIERRE DE EMBUTIR TITÁN CON LLAVE** TITAN RECESSED HANDLE WITH KEY



» Los cierres automontables permiten la apertura, cruce y superposición de las hojas en correderas.

» Sistema de regulación del gancho con acceso desde la parte frontal y sistema de retención mediante tornillo prisionero con el objetivo de evitar el desmontaje.

» Ensamblados para su operación en automático, es posible pasar a modo manual retirando un muelle.

» Self-assembly recessed handle allows the opening, crossing and overlapping of the sashes in sliding windows.

» Hook adjustment system by means of direct access from the front of the lock and retaining system by means of a grub screw to prevent disassembly.

» Assembled for automatic operation, it is possible to switch to manual function by removing a spring.

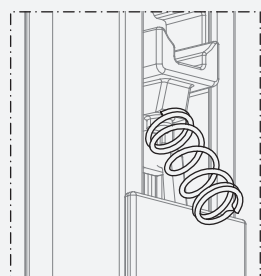
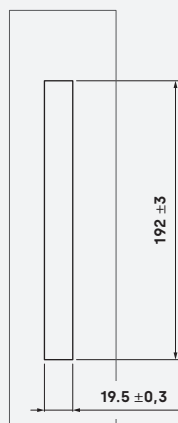

paso de operación automática a manual
switch from automatic to manual

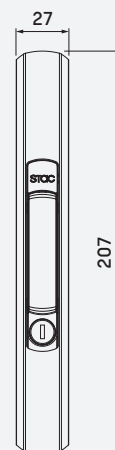

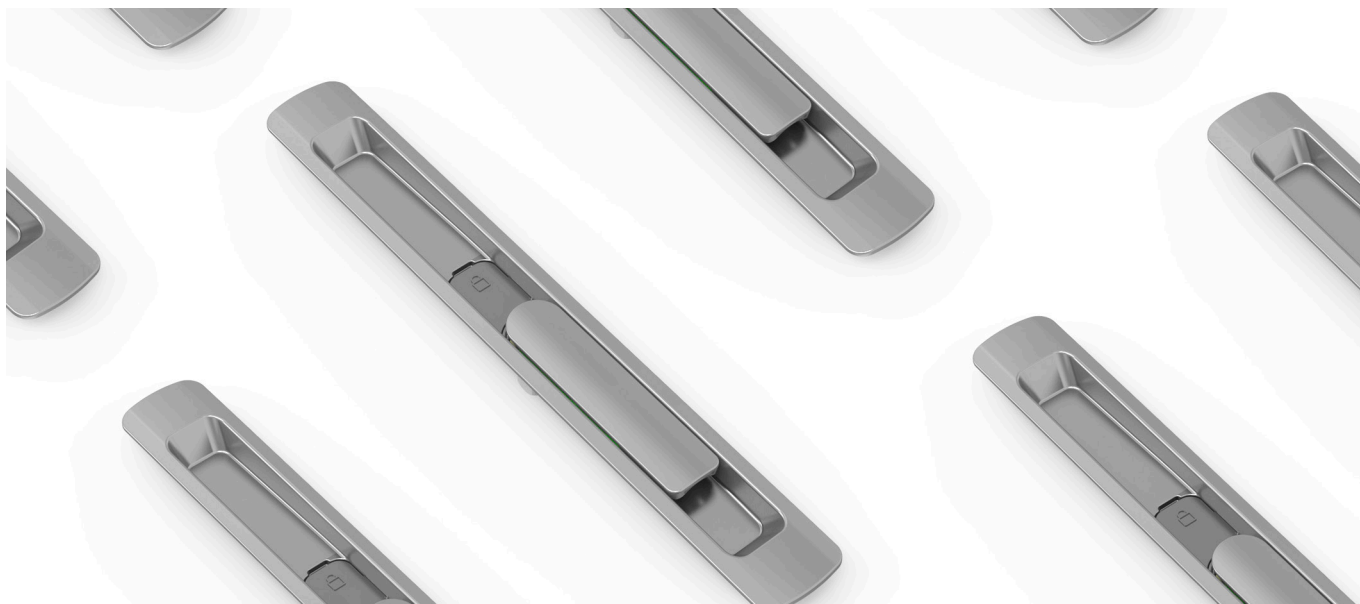

» Manillas enrasadas flush handles

034410	**	MANILLA ENRASADA TITÁN 7 x 15 mm TITAN FLUSH HANDLE 7 x 15 mm
034420	**	MANILLA ENRASADA TITÁN 7 x 25 mm TITAN FLUSH HANDLE 7 x 25 mm
034430	**	MANILLA ENRASADA TITÁN 7 x 12 mm TITAN FLUSH HANDLE 7 x 12 mm
034700	**	MANILLA ENRASADA TITÁN MAX TITAN MAX FLUSH HANDLE



- » Manillas enrasadas con diseño que permite el cruce de hojas en sistema de corredera.
- » Permiten el movimiento del cuadradillo hasta 180°.
- » Sistema de fijación sin tornillería vista que permite mantener la estética minimalista.
- » Incluye tapas embellecedoras de instalación rápida con el objetivo de ocultar los tornillos de fijación.

- » Handle with a flush design that allows the crossing of the sashes in sliding windows.
- » Allow the full 180° movement of the spindle.
- » Attachment to the profile without visible screws to keep the minimalist lines.
- » The product includes fast-assembly cover caps to conceal the fixing screws.

» MANILLA TITÁN MAX FLUSH HANDLE

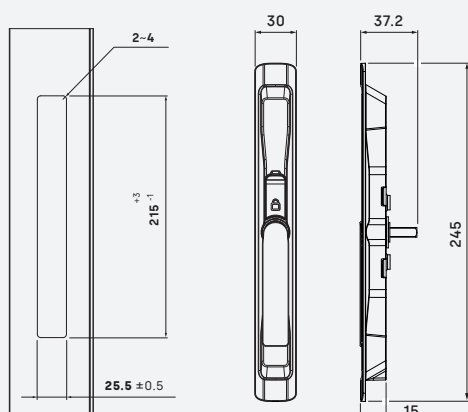

» MANILLA TITÁN FLUSH HANDLE

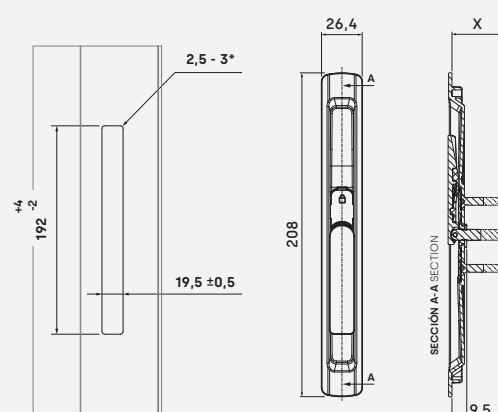

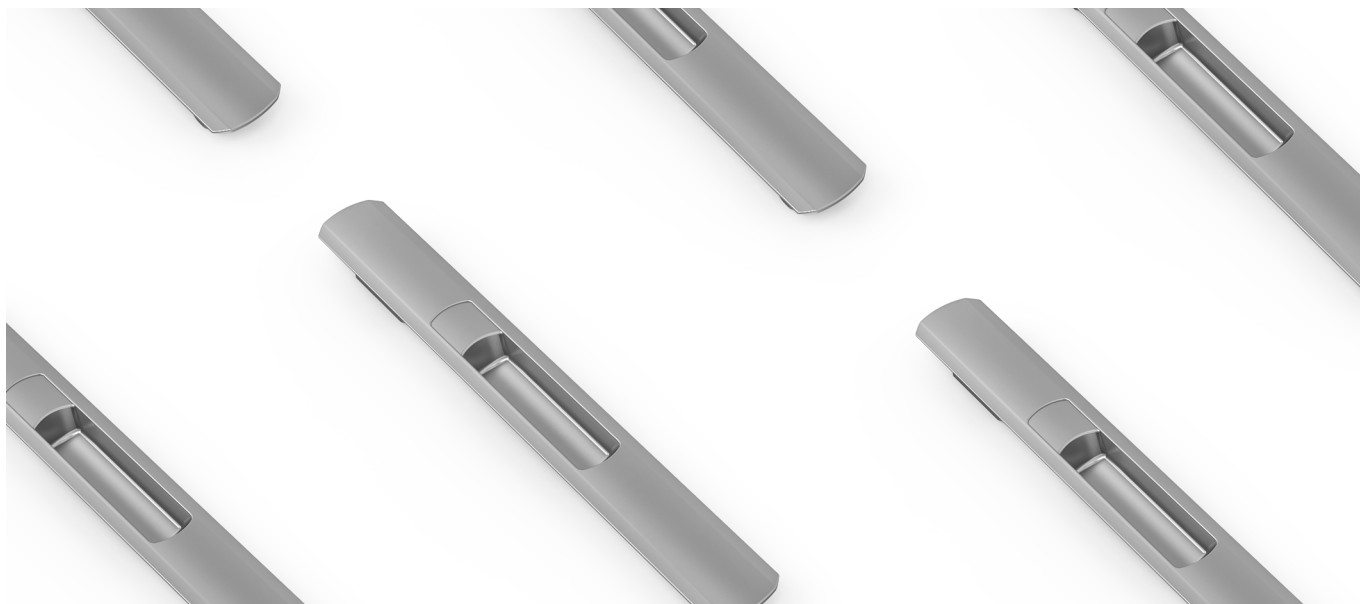

Uñero tirador finger pull

0342000 ** UÑERO TIRADOR TITÁN TITAN FINGER PULL



- » Uñero automontable que permite la apertura de ventanas correderas.
- » Permite realizar el cruce y superposición de las hojas.
- » Fijación rápida al perfil presionando en la parte superior del uñero sin necesidad de utilizar tornillería.

- » Self-assembling finger pull that allows the opening of sliding windows.
- » Allows the crossing and overlapping of the sashes.
- » Screwless fixing to the profile by pressing on the upper part.

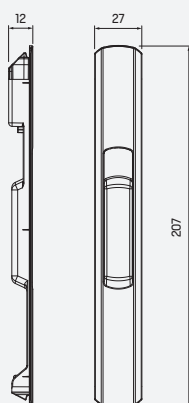
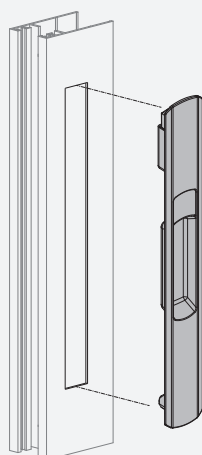

» ANCHO MÍNIMO DE LA HOJA PARA
UÑERO TIRADOR + CIERRE DE EMBUTIR

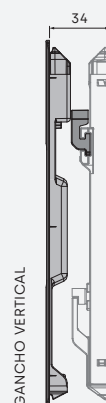

GANCHO VERTICAL

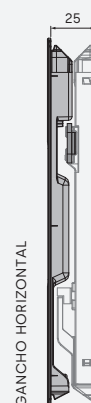

GANCHO HORIZONTAL

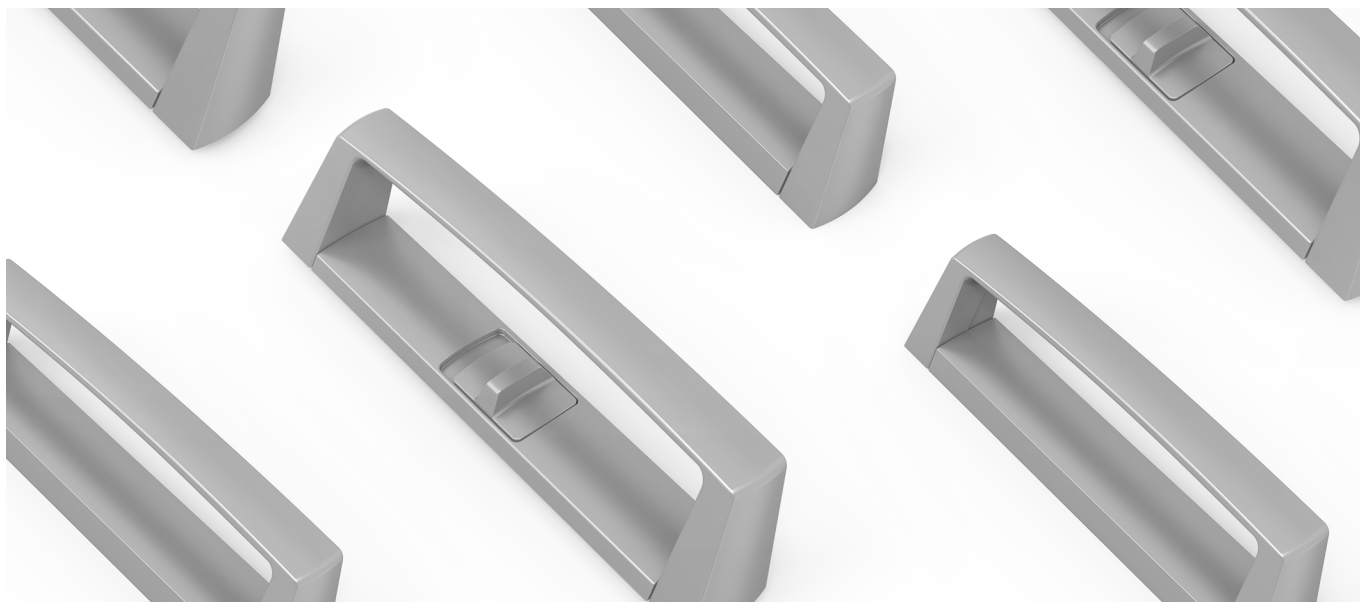

Tiradores pull handles

034500	**	TIRADOR TITÁN BASIC TITAN BASIC PULL HANDLE
034300	**	TIRADOR TITÁN PARA CIERRE DE EMBUTIR TITAN RECESSED PULL HANDLE
034600	**	TIRADOR TITÁN MULTIPUNTO TITAN PULL HANDLE FOR MULTIPOINT LOCK
034800	**	TIRADOR TITÁN FLAP (R) TITAN FLAP PULL HANDLE (R)
034900	**	TIRADOR TITÁN FLAP (L) TITAN FLAP PULL HANDLE (L)



» Tiradores que permite la apertura de ventanas correderas de grandes dimensiones.

» Instalación frontal sin necesidad de realizar mecanizados previos en el perfil.

TIRADOR PARA CIERRE DE EMBUTIR

- » Diseño totalmente integrado que oculta los tornillos de fijación autotaladrantes.
- » Se usa siempre en combinación con un cierre de embutir.

TIRADOR PARA CIERRES MULTIPUNTO

- » Permite realizar el giro de 90° del cuadradillo.
- » Fijación independiente del bloqueo del cierre multipunto.

TIRADOR TITÁN FLAP

- » Adaptable a cierre multipunto con cuadradillo de 7 mm.
- » La leva integrada en la propia base permite reducir el impacto visual del tirador multipunto.

» Pull handles that allows the opening of large sliding windows.

» Front installation of the pull handle without any pre-machining of the profile.

TITAN RECESSED PULL HANDLE

- » Fully integrated design that prevents the vision of the fixing screws.
- » Is always used in combination with a recessed handle.

TITAN PULL HANDLE FOR MULTIPOINT LOCK

- » The mechanism allows the spindle to be rotated by 90°.
- » Fixing is independent of the locking of the multipoint.

TITAN FLAP PULL HANDLE

- » Pull handle adaptable to any multipoint locking system with a 7 mm square.
- » The cam integrated in the base itself reduces the visual impact of the multipoint handle.

► **Tirador titán basic** titan basic pull handle

034500 **

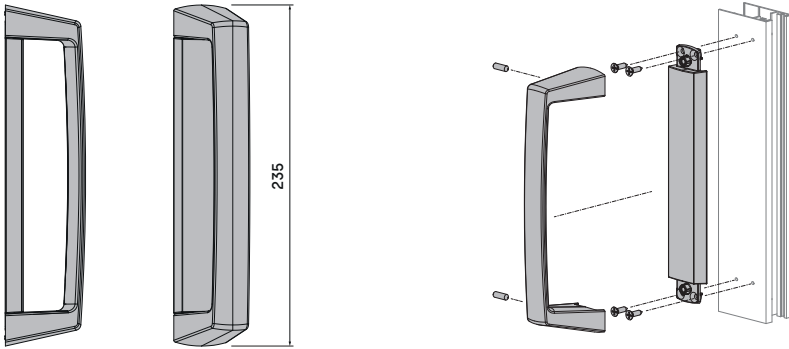

► **Mecanizado** machining

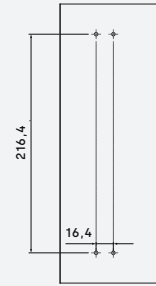

► **Tirador titán para cierre de embutir** titan recessed pull handle

034300 **

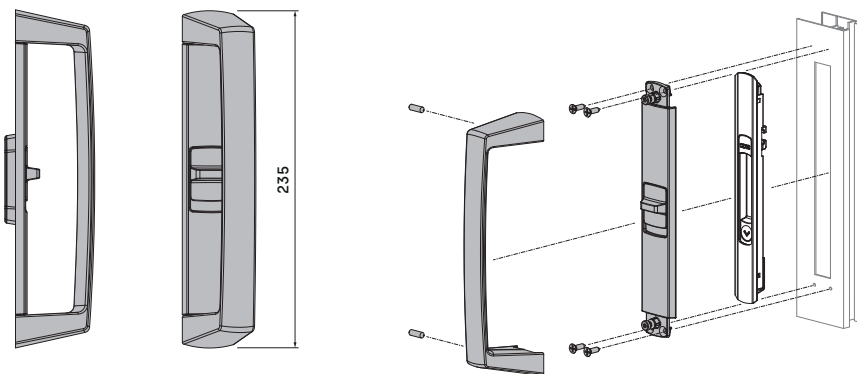

► **Mecanizado** machining

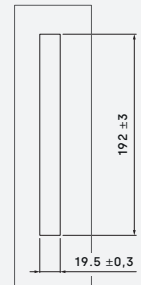

► **Tirador titán multipunto** titan pull handle for multipoint lock

034600 **

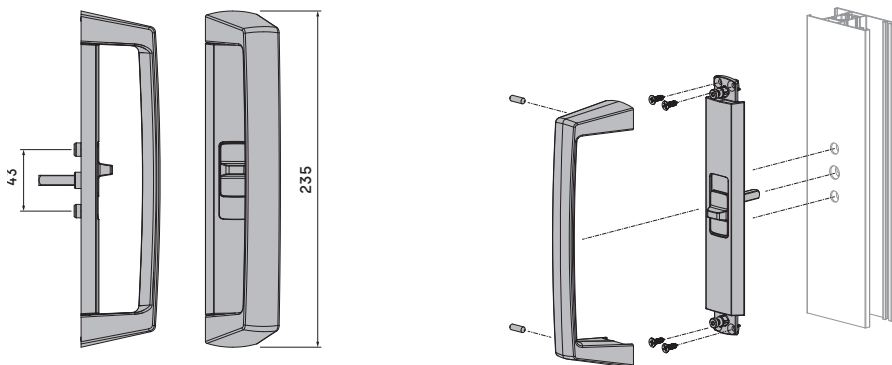

► **Mecanizado** machining

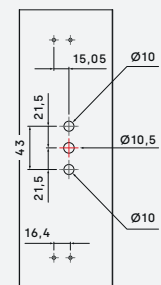

► **Tirador titán flap** titan flap pull handle

034800 **

034900 **

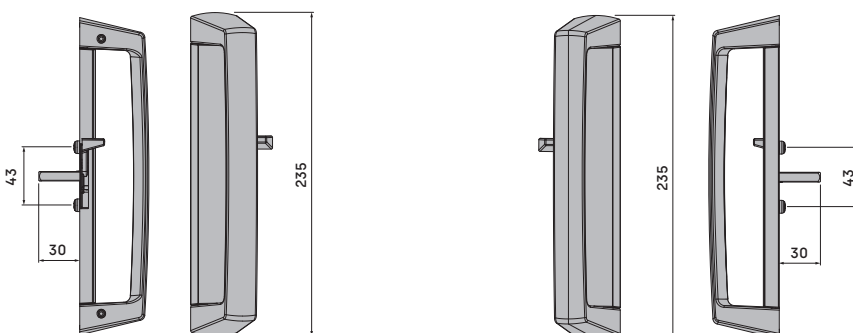

► **Mecanizado** machining

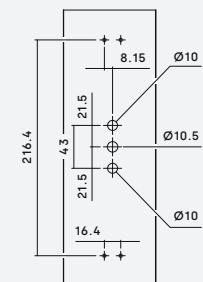

Ganchos frontales front nibs

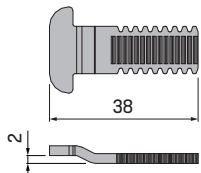
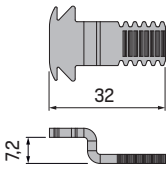
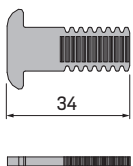
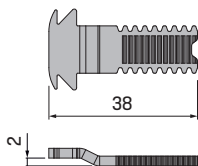
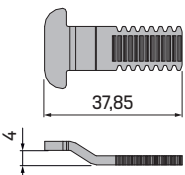
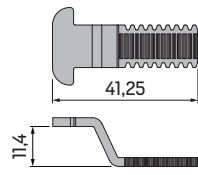
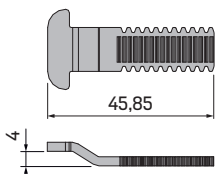
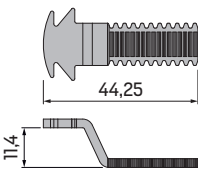
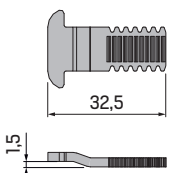
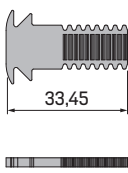
References	Dimensions	References	Dimensions
03150		03148	
03151		03162	
03152		03170	
03153		03172	
03154		03073	

Ganchos perimetrales perimeter nibs

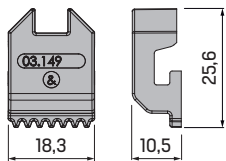
References	Dimensions
0403149	



Compatibles con microventilación
Micro-ventilation compatibility

034000 **

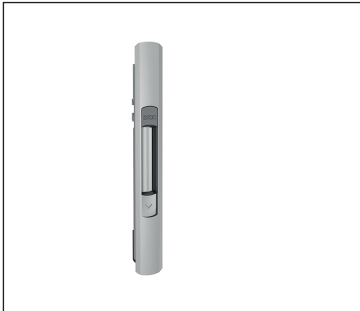

CIERRE DE EMBUTIR TITÁN SIN LLAVE
TITAN RECESSED HANDLE W/O KEY

034100 **



CIERRE DE EMBUTIR TITÁN CON LLAVE
TITAN RECESSED HANDLE WITH KEY

034410 034420 034430 **



MANILLA ENRASADA TITÁN
TITAN FLUSH HANDLE

034700 **



MANILLA ENRASADA TITÁN MAX
TITAN MAX FLUSH HANDLE

0342000 **



UÑERO TIRADOR TITÁN
TITAN FINGER PULL

034500 **



TIRADOR TITÁN BASIC
TITAN BASIC PULL HANDLE

034300 **



TIRADOR TITÁN PARA CIERRE DE EMBUTIR
TITAN RECESSED PULL HANDLE

034600 **



TIRADOR TITÁN MULTIPUNTO
TITAN PULL HANDLE FOR MULTIPOINT LOCK

034800 034900 **



TIRADOR TITÁN FLAP
TIRADOR TITÁN FLAP

** 01 blanco · 02 negro · 91, 92, 93* acabados especiales
white lacquer finish . black lacquer finish . special finishes

* **Consúltenos disponibilidad y fecha de entrega de los acabados.**
Please, contact us for availability and delivery date of the finishes.